



sportworks®

Bike Parking Product Catalog

Bike Parking for Healthy Buildings



We are proud participants in the International Living Future Institute *Declare* program & *Living Building Challenge* (LBC), which generates a nutrition label for building products. All of our Premium No Scratch® products are LBC Red List Free or LBC Red List Approved – the two highest ratings.

We prioritize minimizing our environmental impact and supplying transparency for the life cycle and origins of our products and materials. All Sportworks solutions are proudly designed, engineered, and Made in USA.



Scan to view our current Declare labels

Visit [page 51](#) for more information on the Declare program.

Contents

Introduction	4
Real World Applications	6
Layout Assistance	8
Optimize Your Space	10
Products	
— Premium No-Scratch	14
— 2-Tier + 2-Tier Lift Assist	26
— Premium	34
— Essentials	40
— Bike Lockers	44
— Accessories	46
Materials & Finishes	47
Quick Compare Guide/Product Matrix	48
Sustainability	50
About Sportworks	52



Support Cycling

for a Better Future.

At Sportworks, we don't just manufacture bike parking solutions, we pour our hearts into every single product – because we use them ourselves every day.

We meticulously design and engineer each system in-house, taking personal pride in their functionality. Our commitment to quality and excellence is something that sets us apart from the rest, and we're driven by a passion to craft the best bike parking solutions to elevate your project.

With over 30 years of experience, we offer a wide range of functional, flexible, and durable systems spanning indoor and outdoor, long-term and short-term parking including vertical and horizontal racks, bike lockers, and much more.

Whether you need a custom bike parking layout or assistance choosing the perfect solution to meet your unique needs, our team is here to support you every step of the way.



Functionality.
Reliability.
Ingenuity.
Security.

Real World Applications for Real World Users

Sportworks solutions safely and easily store bicycles across the globe, from university and school campuses to commercial and residential buildings, transit stations, retail spaces, and beyond.



Let Us Help:

Layout Assistance

Our dedicated team of experts is here to help you design bike parking customized to your specific needs - from adhering to regulations and zoning codes, to ensuring proper spacing and setbacks. We offer complimentary consultations and design services to ensure you and your customers receive maximum benefits from your space.

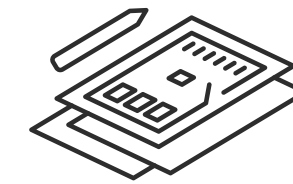
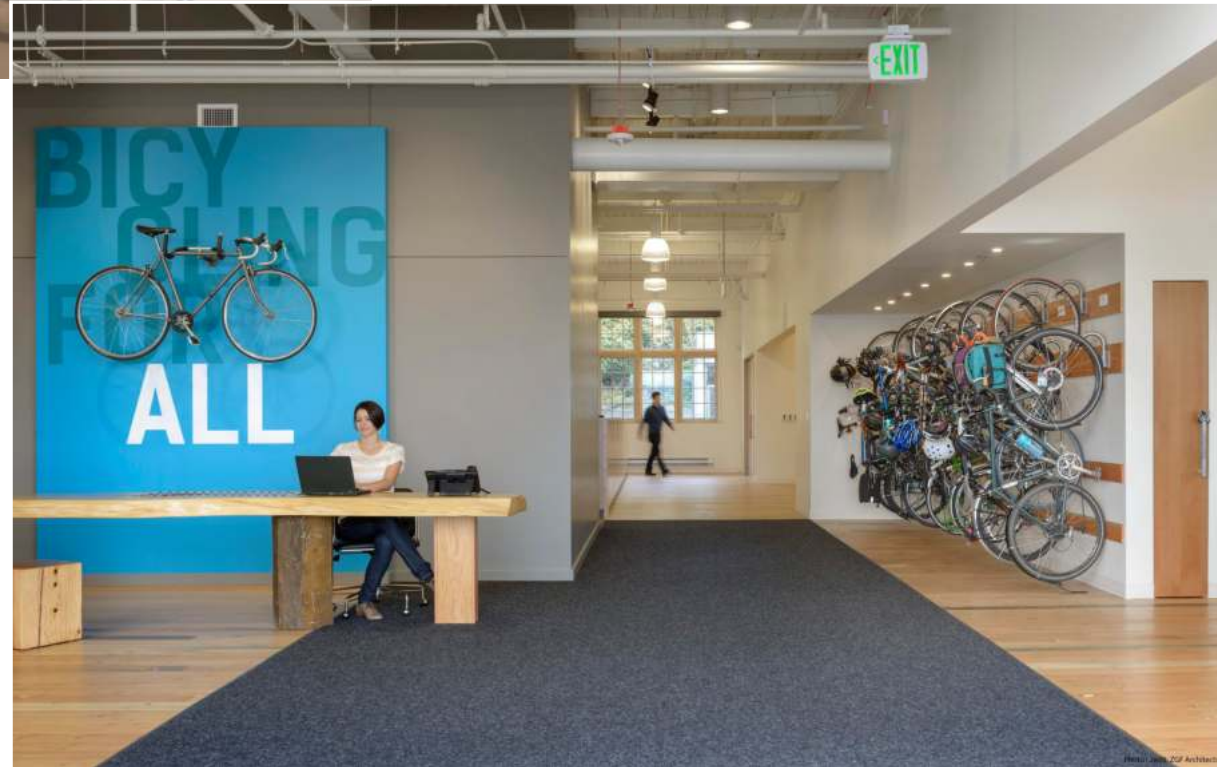

Complimentary Design Services

Let us create a professionally engineered bike parking layout for you, following APBP best practices and local building codes and ordinances.

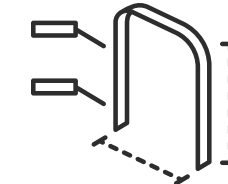

DIY: Downloadable Product Technical Files & Drawings

Our design drawings & models include essential spacing and setbacks to ensure proper planning and successful implementation.



< Learn more about Planning & Layout services



< View available downloads

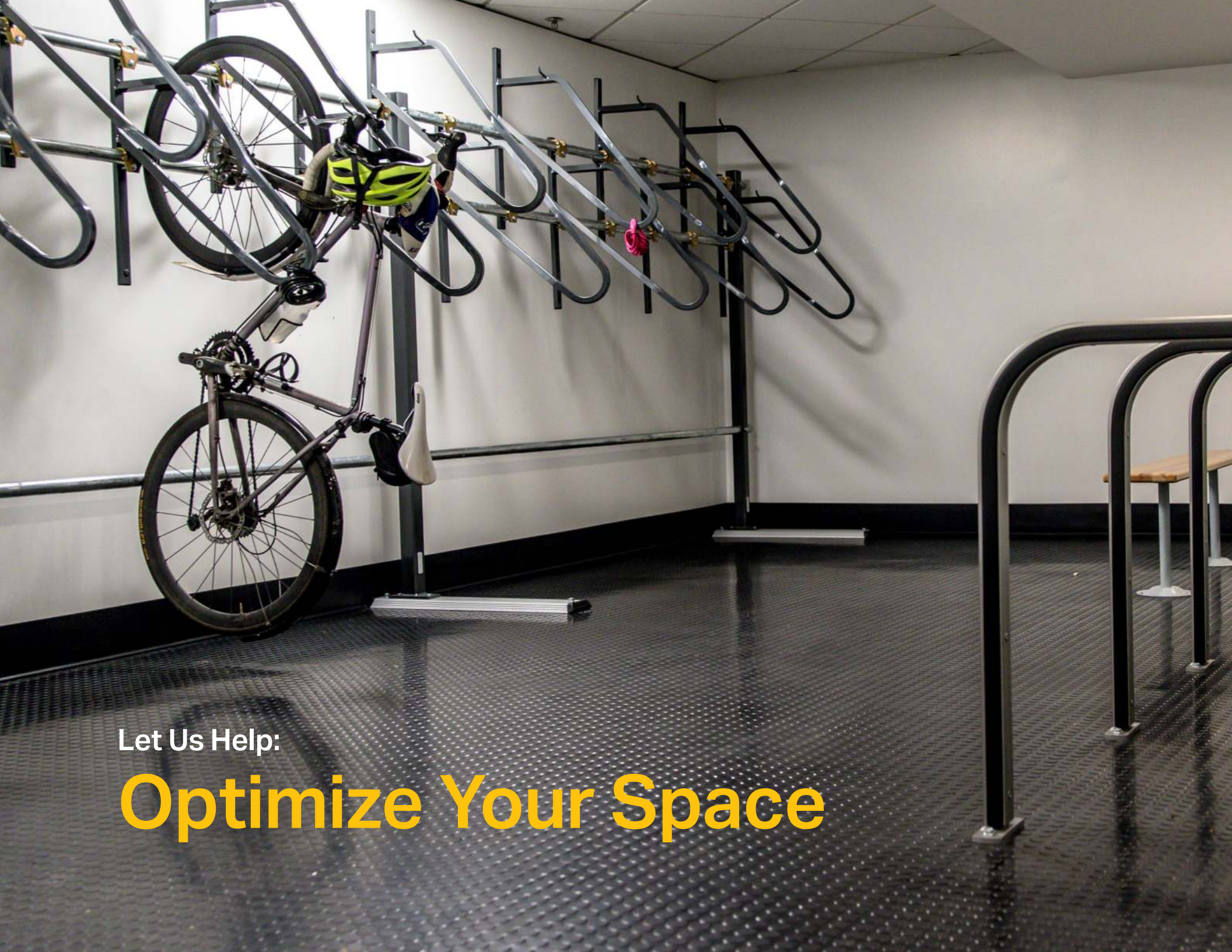

Let Us Help:

Optimize Your Space

What Does Good Bike Parking Look Like?

When creating a bike parking space, the foremost objective is to guarantee functionality and usability. However, there are many other factors that must be taken into consideration for optimal space design. We track the latest developments and bicycle design trends – so you don't have to. Incorporating over 30-years of experience, our team of experts can help design beyond bike parking products to ensure your project results in an efficient, beautiful, and durable space.



Security

Good bike parking should be secure and provide protection against theft and vandalism. Be sure the rack is compatible with a U-lock for maximum security.



Accessibility

Bike parking should be ADA-compliant when placed in circulation paths, and not obstruct pathways and sidewalks.

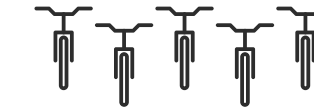

Efficiency

Provide plenty of capacity for bikes while keeping a small footprint. It's important to have sufficient space between bikes to prevent them from becoming entangled or damaged.



Durability

The bike rack or parking system should be durable and maintain an attractive appearance even with exposure to the elements and constant use. It should also be able to support the weight of the bike without damaging it.



Flexibility

The bike parking system should be compatible with different types of bikes, including those with varying frame sizes, wheel sizes, and styles.



Ease of use

Bike parking should be intuitive, easy to use, and require minimal effort. This is important to encourage more people to use bikes as a form of transportation.



Visibility

Good bike parking should be visible from nearby roads and paths. This helps to increase awareness of cycling and promotes the use of bikes as a mode of transportation.

 Educational Live Webinars

Earn AIA or ASLA credits, learn about APBP standards, the Declare Program's Living Building Challenge, and LEED requirements.

Get Started at sportworks.com

Bike Parking Solutions

- Premium No-Scratch® Bike Parking
- 2-Tier Lift Assist + 2 Tier
- Premium Standard
- Essentials
- Bike Lockers
- Accessories
- Materials & Finishes



Premium No Scratch® Bike Parking

HORIZONTAL:

Tofino™ No Scratch® Bike Rack (+ ADA version)

Westport™ No Scratch® Bike Rack

Oahu™ No Scratch® Bike Rack

Omnium™ No Scratch® Bike Rack

VERTICAL:

Vertical+™ No Scratch® Bike Rack



Declare.



Sportworks' proprietary *No Scratch*® integrated bumper protects the bicycle and the rack from scratches and dents.

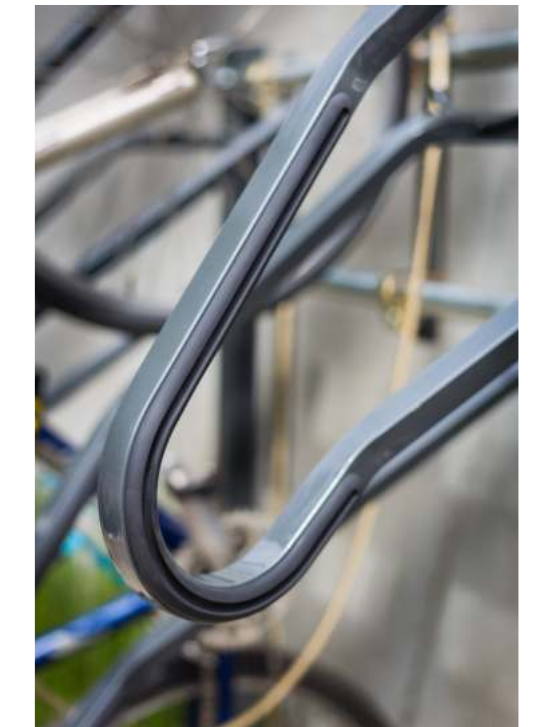

Vandal-resistant and durable,
No Scratch supplies a premium
and exclusive bike parking
experience for cyclists.

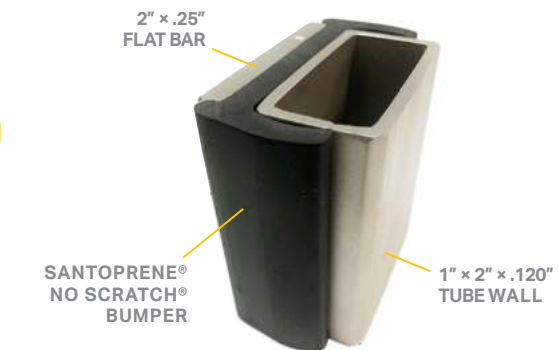

HORIZONTAL

Tofino™ No Scratch® Bike Rack

A unique combination of beautiful aesthetics and superior functionality. With a modern design and integration of the Sportworks No Scratch bumper that protects bikes, and the rack from damage, the Tofino sets a new standard for bike parking.

The Tofino offers high space efficiency and superior flexibility for parking virtually any size or type of bicycle or scooter.

The cane detectable cross-bar option complies with the 2010 ADA Standards for Accessible Design, Chapter 3, Section 307.3, for post-mounted objects in circulation paths.

- Materials:** Stainless or Mild Steel (ADA version stainless steel only)
- Mount:** Surface, Embedded, or Rails
- Security:** U-Lock Compatible
- Install:** Indoor or Outdoor
- Capacity:** 2 per rack
- Density Rating:** ★★★★★



Tofino

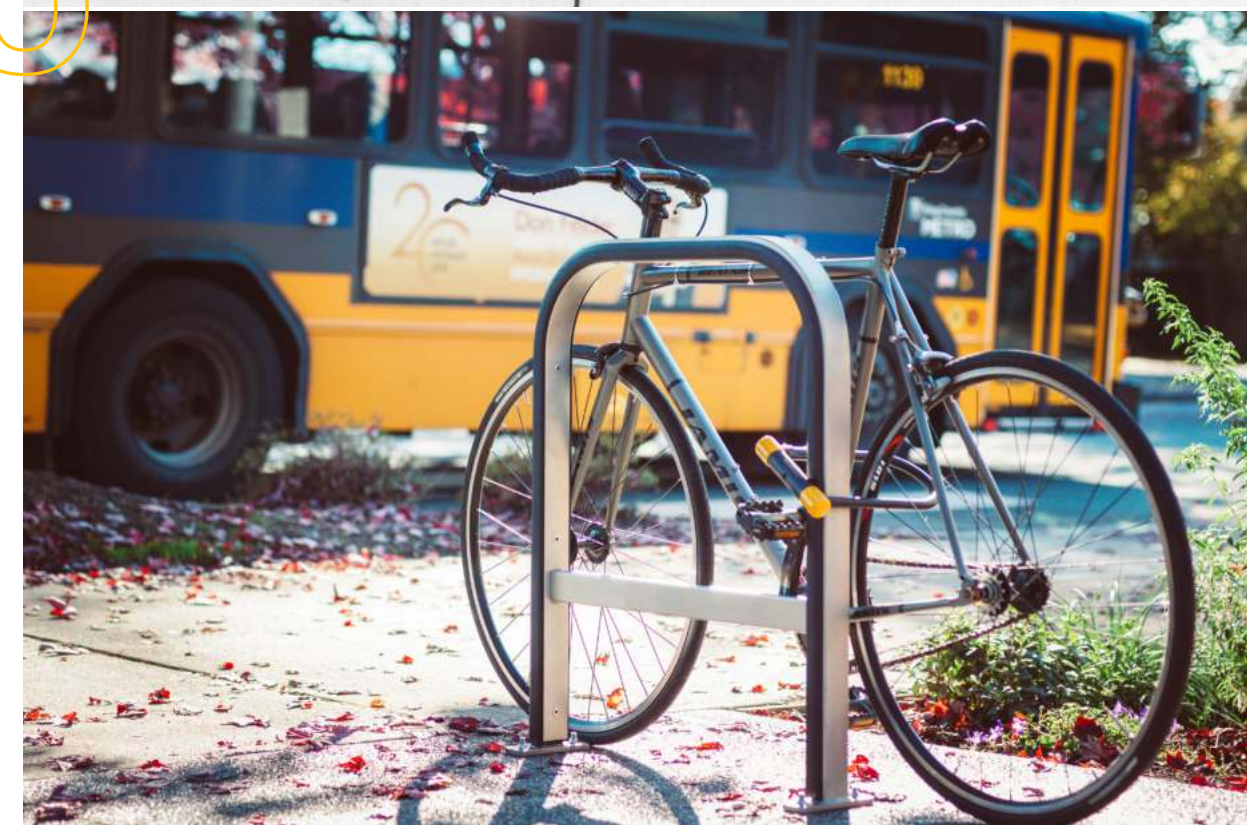

CANE DETECTABLE OPTION (ADA Compliant)



Learn more about ADA Compliant bike parking racks

HORIZONTAL

Westport™ No Scratch® Bike Rack

The Westport rack has a compact footprint and is ideal for locations where versatility and shared pedestrian space is important. The No Scratch® bumper keeps bicycles damage-free.

- Materials:** Stainless or Mild Steel
- Mount:** Surface, Embedded, or Rails
- Security:** U-Lock Compatible
- Install:** Indoor or Outdoor
- Capacity:** 2 per rack
- Density Rating:** ★★★★★

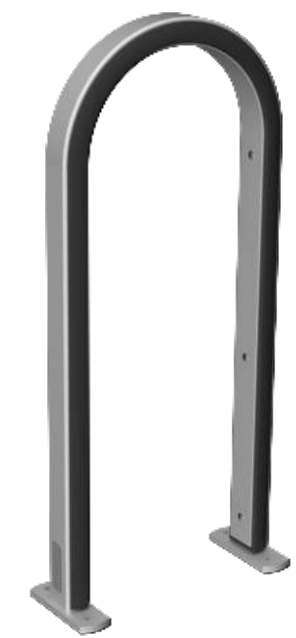

Westport



Declare.



Oahu



Materials: Stainless or Mild Steel

Mount: Surface or Embedded

Security: U-Lock Compatible

Install: Indoor or Outdoor

Capacity: 2 per rack

Density Rating: ★ ★ ★ ★ ★

HORIZONTAL

Oahu™ No Scratch® Bike Rack

The Oahu bike parking rack brings our exclusive bike No Scratch bike protecting bumper to this fluid, circular design. The Oahu offers flexible, high density parking efficiency for two bikes for sidewalks, campuses, bike rooms, city parks or anywhere flexibility and design are desired.



Declare.



Omnium



Materials: Stainless or Mild Steel

Mount: Surface or Embedded

Security: U-Lock Compatible

Install: Indoor or Outdoor

Capacity: 2 per rack

Density Rating: ★★★★★

HORIZONTAL

Omnium™ No Scratch® Bike Rack

A horizontal rack designed to provide high density and orderly parking with optimal aesthetics and streetscape appeal. Staggered design minimizes bike-to-bike interference, entanglement, and allows all bikes to be parked in the same direction without creating handlebar interference. Omnium is ideal for destination parking where wheel-well support is key.



Declare.

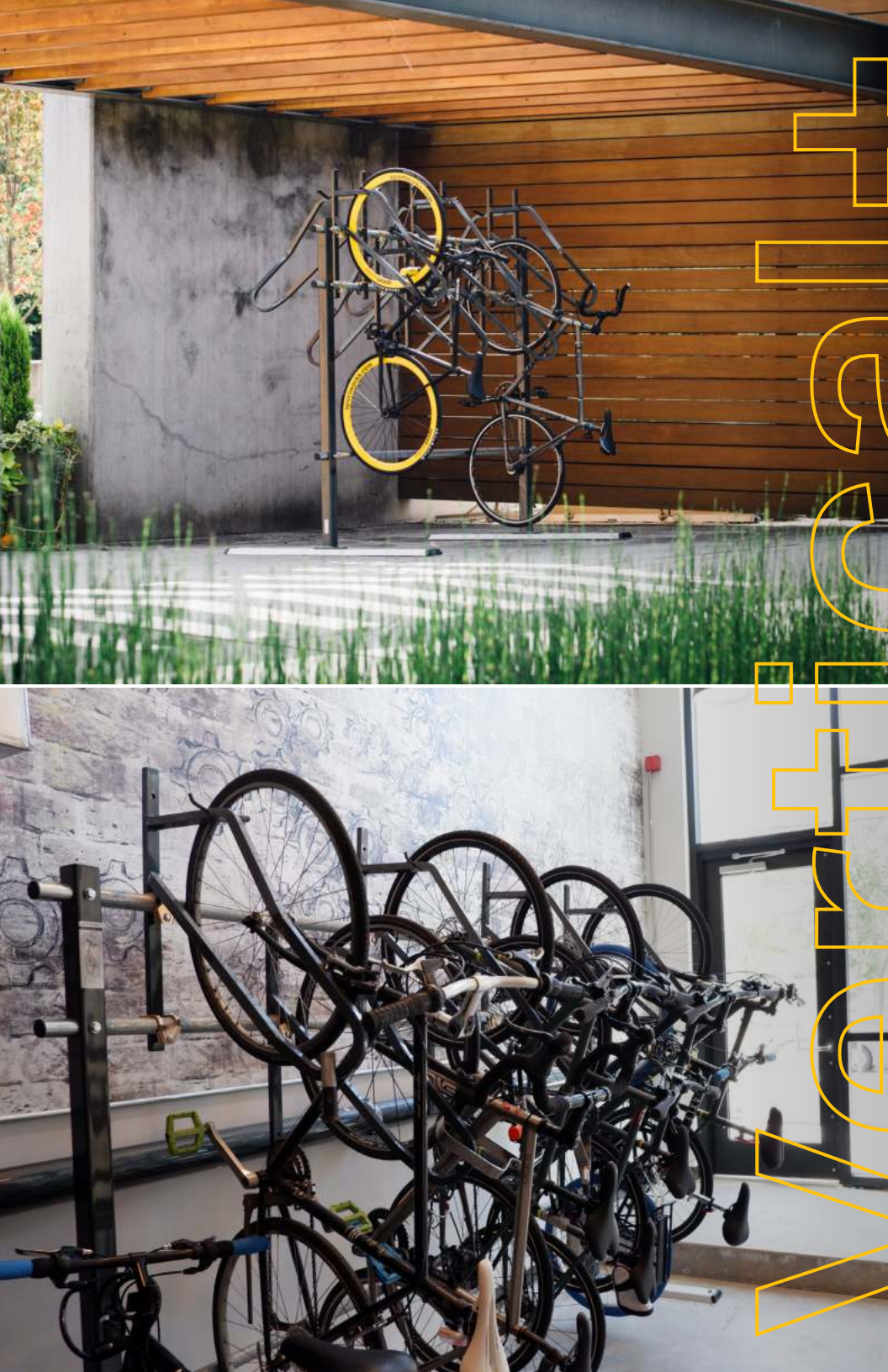

VERTICAL+

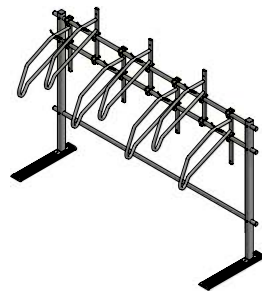

FLOOR MOUNT, SINGLE-SIDED

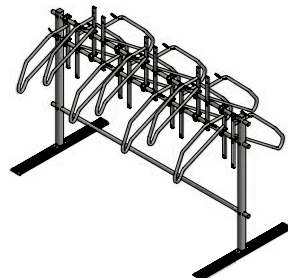

FLOOR MOUNT, DOUBLE-SIDED



WALL MOUNT



DIRECT WALL MOUNT

Materials:
 Mild Steel and Aluminum (*floor & wall mounts*)
 Mild Steel (*direct wall mounts*)

Mount: Floor, Wall, Direct Wall

Security: U-Lock Compatible

Install: Indoor or Covered Outdoor

Single-Sided Capacity:
 2-7 per module, can daisy-chain

Double-Sided Capacity:
 4, 6, 8, 10, 12, or 14 per module, can daisy-chain

Direct Wall Mount Capacity:
 1 per mount

Density Rating: ★★★★★

VERTICAL

Vertical+™ No Scratch® Bike Rack

The Vertical+ No Scratch is the most space-efficient vertical bicycle rack for high-density bicycle parking. Endless configurability allows for a myriad of layouts to optimize available space for bicycle parking. Standard racks without No-Scratch® technology are also available.



Declare.



< Read about the art of bike room design

2-Tier Lift Assist + 2-Tier

2-TIER LIFT ASSIST

VelopA Easylift Premium

VelopA CapaCITY

2-TIER

Terrace™ High Density Bike Parking System



2-Tier and 2-Tier Lift Assist solutions maximize efficiency of space & provide high density.



HORIZONTAL

VelopA Easylift Premium

Direct from the Netherlands, the bicycling capital of the world, comes the market leading VelopA Easylift Premium two-tier bike parking rack. Lightweight aluminum upper trays require minimal lifting effort and dampers provide a controlled hands-free descent.

Materials: Mild Steel and Aluminum

Mount: Floor

Security: U-Lock Compatible

Install: Indoor or Outdoor

Single-Sided Capacity:
4, 8, 10, 12, or 16 per module,
infinitely linked or stand-alone

Double-Sided Capacity:
8, 16, 24, 28, or 32 per module,
infinitely linked or stand-alone

Density Rating: ★★★★★



VelopA Easylift



HORIZONTAL

VelopA CapaCITY

Gas springs provide lift assistance for the user, and the all steel design is extremely durable. The VelopA CapaCITY is our most cost-effective two-tier rack to maximize bike density.

Materials: Mild Steel

Mount: Floor

Security: U-Lock Compatible

Install: Indoor or Outdoor

Single-Sided Capacity:
4, 8, 10, 12, or 16 per module, infinitely linked or stand-alone

Double-Sided Capacity:
8, 16, 24, 28, or 32 per module, infinitely linked or stand-alone

Density Rating: ★★★★★

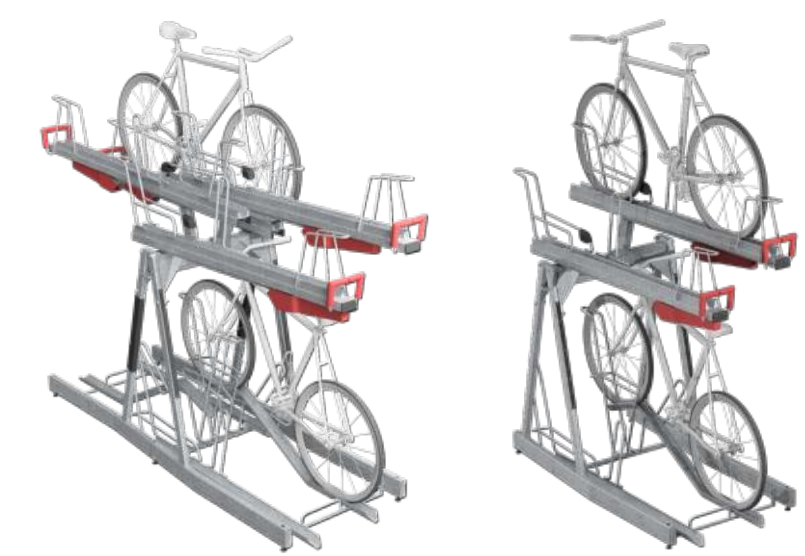

VelopA CapaCITY



Terrace



Materials: Mild Steel

Mount: Floor

Security: U-Lock Compatible

Install: Indoor or Covered Outdoor

Single-Sided Capacity:
4, 6*, 8, or 12 options per module,
infinitely linked or stand-alone

Double-Sided Capacity:
8, 12*, 16, or 24 options per module,
infinitely linked or stand-alone

Density Rating: ★★★★★

**Extension only*

VERTICAL

Terrace™ High Density Bike Parking System

Modular and configurable to fit virtually any space, the Terrace system is optimized for easy assembly and supplies the best stability and fastest installation of two-tier parking systems.

Premium

HORIZONTAL:

Plaza High Density Bike Rack

Plaza Jr. High Density Bike Rack



High density, organized, intuitive, and space efficient bike parking all within a beautiful sculptural design.

HORIZONTAL

Plaza High Density Bike Rack

Our Plaza bike racks promote orderly parking. With its “zero clearance” mounting capability, the single sided 6-bike rack can be installed directly next to a building or structure, maximizing space efficiency. The double sided 12-bike rack maximizes space use and capacity without increasing the length of the rack. This rack is ADA compliant.

Materials: Stainless or Mild Steel

Mount: Surface

Security: U-Lock Compatible

Single-Sided Capacity: 4 or 6

Double-Sided Capacity: 8 or 12

Density Rating: ★★★★★

Install: Indoor or Outdoor

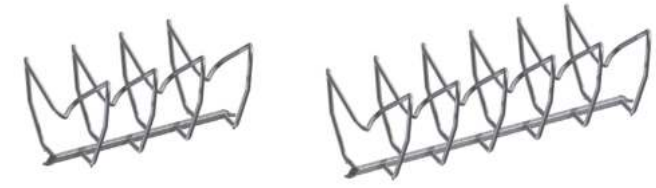
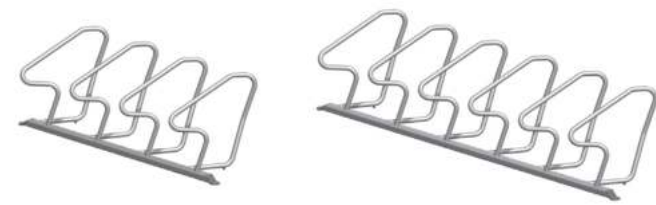

Plaza



Plaza Jr.

HORIZONTAL

Plaza Jr. High Density Bike Rack

The Plaza Jr. bike parking rack is available as a 6-bike single sided rack or 12-bike double sided rack. The perfect bike parking solution for kids' bikes, the Plaza Jr. promotes orderly parking and is ideal for playgrounds and schools.

- Materials: Stainless or Mild Steel
- Mount: Surface
- Security: U-Lock Compatible
- Single-Sided Capacity: 6
- Double-Sided Capacity: 12
- Density Rating: ★★★★★
- Install: Indoor or Outdoor

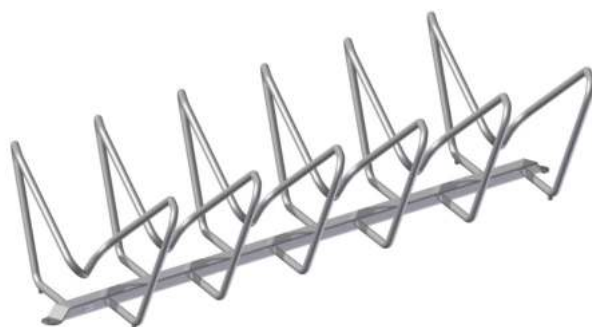
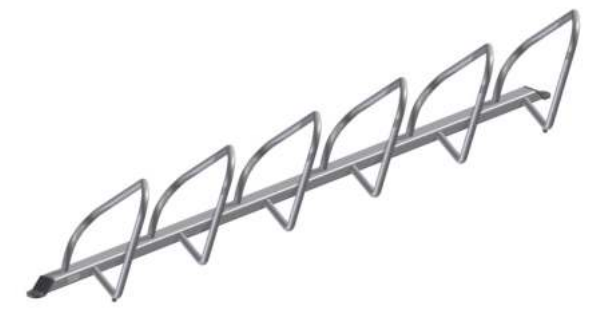

Essentials

HORIZONTAL:

- Inverted U
- Post Bike Rack
- Interbay™ Wall Mounted Bike Rack

VERTICAL:

- Crossroads™ Wall Mounted Bike Rack

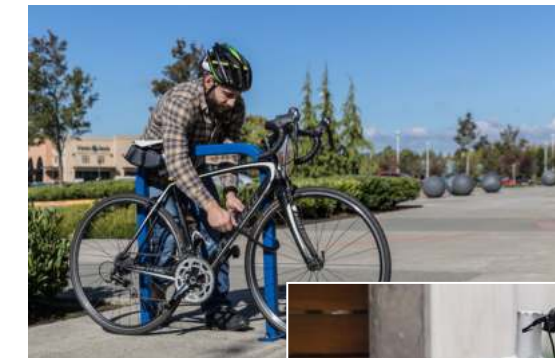
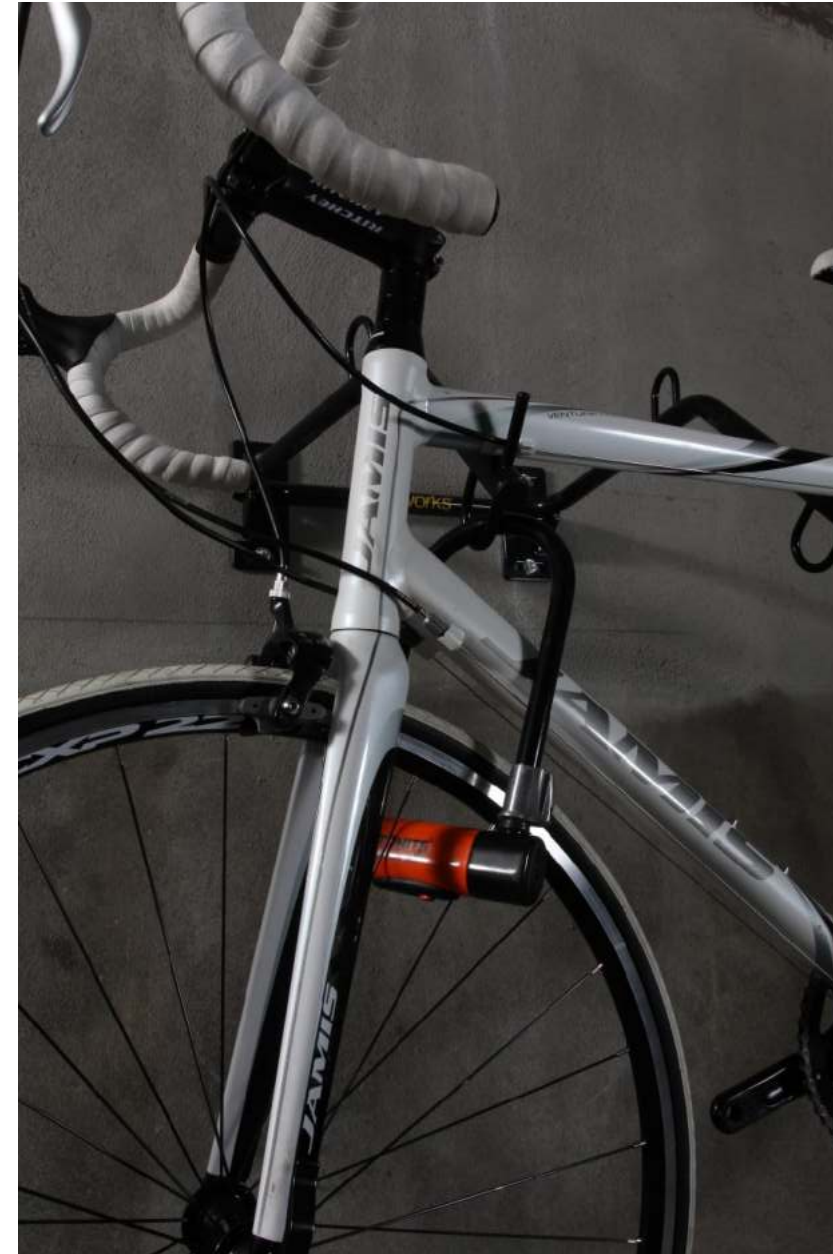

Inverted U

Our Inverted U racks combine the elements of high security with ease of use. Options for ADA Compliance, Wide, and Heavy Duty.



Materials: Stainless or Mild Steel
Mount: Surface, Embedded, Rails
Security: U-Lock Compatible

Install: Indoor or Outdoor
Capacity: 2 per rack
Density Rating: ★★★★★

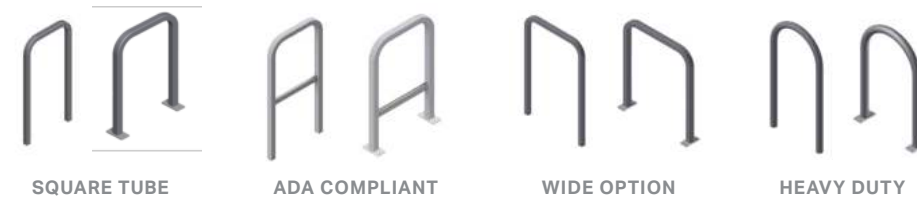

Post Bike Rack

A simple space efficient design created for sidewalks and other narrow spaces; prevents the protrusion of bikes into the sidewalk and street.

Materials: Stainless or Mild Steel
Mount: Surface or Embedded
Security: U-Lock Compatible

Install: Indoor or Outdoor
Capacity: 2 per rack
Density Rating: ★★★★★



Interbay™ Wall Mounted Bike Rack

The Interbay has a simple, intuitive design created for high use areas and is perfect for vertical parking within a small space, such as an office, parking garage, or lobby.

Materials: Mild Steel
Mount: Direct Wall
Security: U-Lock Compatible
Install: Indoor or Outdoor

Single Capacity: 1 per rack
Double Capacity: 2 per rack
Density Rating: ★★★★★

Crossroads™ Wall Mounted Bike Rack

The Crossroads has a simple, intuitive design perfect for multi-family residential, mixed-use, office, lobby, or showcase bike rooms.

Materials: Stainless Steel
Mount: Direct Wall
Security: U-Lock Compatible*

Install: Indoor or Outdoor
Capacity: 1 per rack
Density Rating: ★★★★★



*Optional

Bike Lockers

HORIZONTAL



Single Bike Locker (Standard or Wedge)

Materials: Stainless or Mild Steel

Mount: Floor

Security: Various Locking Options

Install: Indoor or Outdoor

Capacity: 1 per locker

Density Rating: ★★★★★

Two Bike Locker

Materials: Stainless or Mild Steel

Mount: Floor

Security: Various Locking Options

Install: Indoor or Outdoor

Capacity: 2 per locker

Density Rating: ★★★★★

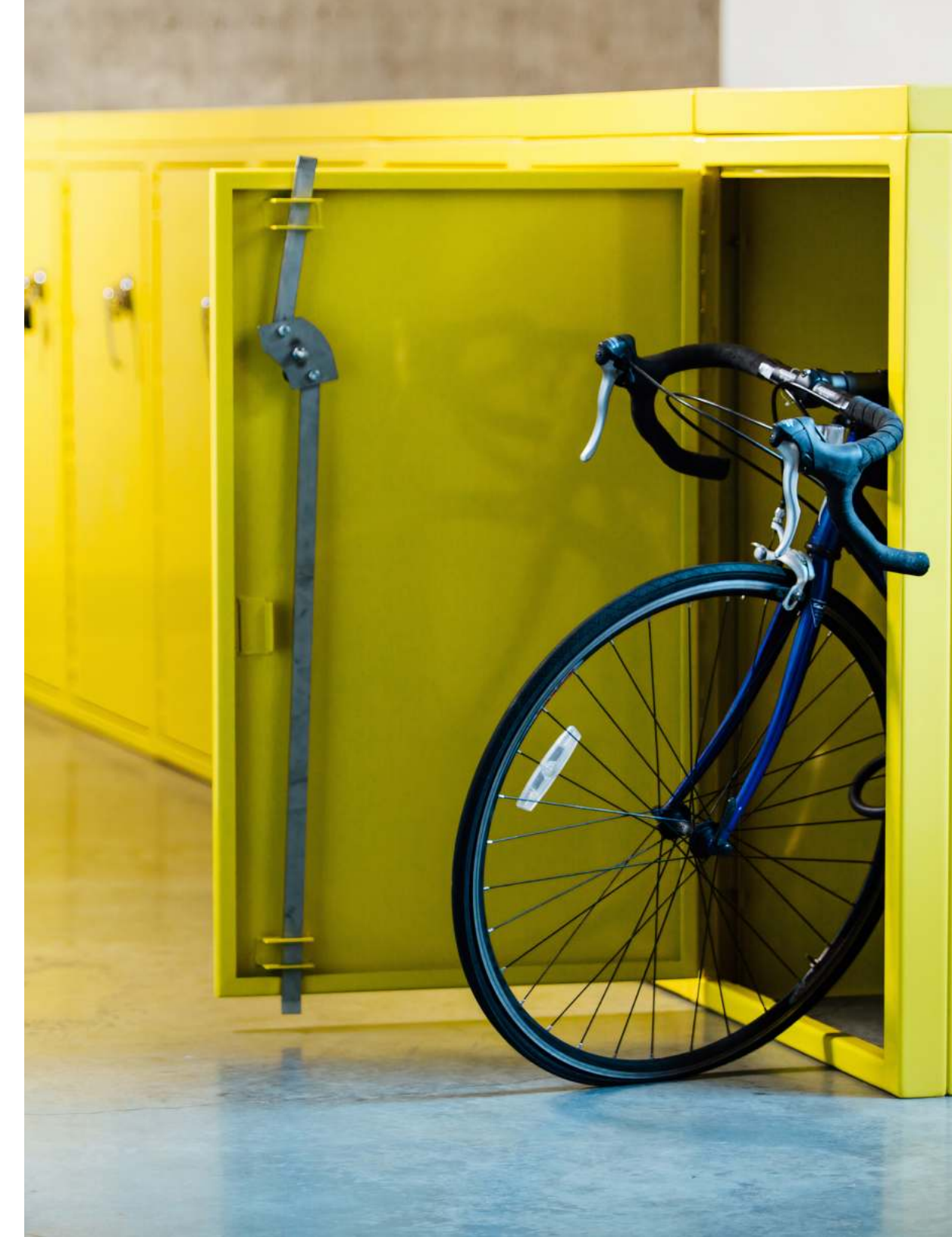

Accessories



Whether your bike parking project is a VIP bike room, or a parking garage, supplying amenities like repair stands and bike pumps make the space more desirable.

PUBLIC WORK STAND



DELUXE PUBLIC WORK STAND



OUTDOOR PUBLIC BIKE PUMP



Designing your bike room?
Our experts are here to help.



< Scan to request layout assistance



Materials & Finishes



MILD STEEL

Mild steel racks are available with a **hot-dipped galvanized finish**. This supplies a durable and stable appearance that is resistant to rust and corrosion. **Powder coat** and **thermoplastic finishes** are also available in a variety of colors.



STAINLESS STEEL

Stainless steel is more resistant to stains, corrosion, and rust, as it contains more chromium and nickel than mild steel. Stainless steel racks are available with a **bead blast finish**, which ages beautifully and supplies long-lasting protection against corrosion. **Powder coat** and **thermoplastic finishes** are also available in a variety of colors.



Add Color with Powder Coating

Powder coat and thermoplastic finishes add an additional layer of corrosion protection to bike racks. Powder coating is available in a wide range of colors. Contact us for a full palette.



< View solution submittal sheets for available material & finish options



Quick Compare Matrix

Model Family	Bike Position	Mount	Materials	Spacing & Configuration Options
Tofino	Horizontal	Surface, Embedded, or Rails	Stainless or Mild Steel	
Tofino, ADA-Compliant	Horizontal	Surface, Embedded, or Rails	Stainless Steel	
Westport	Horizontal	Surface, Embedded, or Rails	Stainless or Mild Steel	
Oahu	Horizontal	Surface or Embedded	Stainless or Mild Steel	
Omnium	Horizontal	Surface or Embedded	Stainless or Mild Steel	
Vertical + No-Scratch	Vertical	Floor	Mild Steel & Aluminum	Single or double-sided with spacing options: 13", 16", 17", or 18"
Vertical + No-Scratch	Vertical	Wall	Mild Steel	Spacing options: 13", 16", 17", or 18"
Vertical + No-Scratch	Vertical	Direct Wall	Mild Steel	Accommodates ANY spacing
VelopA Easylift Premium, Single-Sided	Horizontal	Floor	Mild Steel & Aluminum	Spacing options: 15", 16", 18", or 20"
VelopA Easylift Premium, Double-Sided	Horizontal	Floor	Mild Steel & Aluminum	Spacing options: 15", 16", 18", or 20"
VelopA CapaCITY, Single-Sided	Horizontal	Floor	Mild Steel	Spacing options: 15", 16", 18", or 20"
VelopA CapaCITY, Double-Sided	Horizontal	Floor	Mild Steel	Spacing options: 15", 16", 18", or 20"
Terrace, Single-Sided	Horizontal	Floor	Mild Steel	16" Spacing
Terrace, Double-Sided	Horizontal	Floor	Mild Steel	16" Spacing
Plaza, Single-Sided	Horizontal	Surface	Stainless or Mild Steel	
Plaza, Double-Sided	Horizontal	Surface	Stainless or Mild Steel	
Plaza Jr, Single-Sided	Horizontal	Surface	Stainless or Mild Steel	
Plaza Jr, Double-Sided	Horizontal	Surface	Stainless or Mild Steel	
Vertical+	Vertical	Floor	Mild Steel & Aluminum	Single or double-sided with spacing: 13", 16", 17", or 18"
Vertical+	Vertical	Wall	Mild Steel	Spacing options: 13", 16", 17", or 18"
Vertical+	Vertical	Direct Wall	Mild Steel	Accommodates ANY spacing
Square Tube Inverted U	Horizontal	Surface, Embedded, or Rails	Stainless or Mild Steel	
Square Tube Inverted U, ADA-Compliant	Horizontal	Surface, Embedded, or Rails	Stainless or Mild Steel	
Square Tube Inverted U, Wide	Horizontal	Surface, Embedded, or Rails	Stainless or Mild Steel	
Heavy Duty Inverted U	Horizontal	Surface, Embedded, or Rails	Stainless or Mild Steel	
Post Rack	Horizontal	Surface or Embedded	Stainless or Mild Steel	
Interbay	Horizontal	Direct Wall	Mild Steel	
Crossroads	Vertical	Direct Wall	Stainless Steel	Optional cable or chain makes U-lock compatible
Single Bike Locker, Standard	Horizontal	Floor	Stainless or Mild Steel	Stackable, Wedge Option, U-lock compatible handle
Two Bike Locker	Horizontal	Floor	Stainless or Mild Steel	Stackable, U-lock compatible handle

No-Scratch	Outdoor Install, Uncovered	ADA Compliant	U-Lock Compatible	Wheel-Well Secure	Long Wheelbase Compatible	Density	Capacity	Environmental Declaration	Made in USA
●	●		●		●	★★★★★	2 per rack	Declare.	✓
●	●	●	●		●	★★★★★	2 per rack	Declare.	✓
●	●	●	●		●	★★★★★	2 per rack	Declare.	✓
●	●		●	●	●	★★★★★	2 per rack	Declare.	✓
●			●			★★★★★	1s: 2+, 2s: 4+	Declare.	✓
●			●			★★★★★	2-7	Declare.	✓
●			●			★★★★★	1	Declare.	✓
			●	●		★★★★★	4, 6*, 8, 12 +		✓
			●	●		★★★★★	8, 12*, 16, 24 +		✓
	●		●	●		★★★★★	4, 8, 10, 12, 16 +		
	●		●	●		★★★★★	8, 16, 24, 28, 32 +		
	●			●		★★★★★	4, 8, 10, 12, 16 +		
	●		●	●		★★★★★	8, 16, 24, 28, 32 +		
	●	●	●		●	★★★★★	4 or 6 per rack		✓
	●	●	●		●	★★★★★	8 or 12 per rack		✓
	●	●	●		●	★★★★★	6 per rack		✓
	●	●	●		●	★★★★★	12 per rack		✓
			●			★★★★★	1s: 2+, 2s: 4+	Declare.	✓
			●			★★★★★	2-7	Declare.	✓
			●			★★★★★	1	Declare.	✓
	●		●		●	★★★★★	2 per rack		✓
	●	●	●		●	★★★★★	2 per rack		✓
	●		●		●	★★★★★	2 per rack		✓
	●		●		●	★★★★★	2 per rack		✓
	●		●		●	★★★★★	2 per rack		✓
			●			★★★★★	1-2		✓
	●		○			★★★★★	1 per rack		✓
	●	●	○			★★★★★	1		✓
	●	●	○			★★★★★	2		✓

○ = Optional

*Extension only

Premium No-Scratch

2-Tier & 2-Tier Lift Assist

Premium

Essential

Lockers

Be the Catalyst for Change.

We are passionate about cycling and we take pride in joining forces with those who serve as powerful voices, educators, and mobilizers of active transportation.

Together, we collaborate to support cycling, green building initiatives, sustainability efforts, building community and improving mobility, among other worthy causes. Our shared goal is to make a genuine difference in shaping a better future.

As the landscape evolves and our collective vision of excellence becomes clearer, we are excited to share our expertise and insights. Through our contributions in bike parking and transport solutions, we strive to contribute to establishing guidelines and providing innovative solutions that pave the way for a brighter tomorrow - **together**.



Living Building Challenge

COMMITTED TO SUSTAINABILITY: DECLARE™ LISTED BIKE RACKS

Our dedication to sustainability and the environment goes beyond providing infrastructure for zero-emission transportation. As proud participants in the International Living Future Institute DECLARE program since 2014, we strive to expand transparency in the building market and create a healthier, more sustainable world for all.

We prioritize minimizing our environmental impact and supplying transparency for the life cycle and origins of our products and materials. With these values in mind, we design our products and source materials accordingly. All Sportworks solutions are proudly designed, engineered, and Made in USA.



< Scan to view our current Declare labels





For the love of bikes.
And the future.

About sportworks®

With a rich history spanning over 30 years, Sportworks has been a pioneer in designing and manufacturing purposeful, meticulously engineered products that promote the use of bicycles as an environmentally-friendly and cost-effective mobility solution.

Providing an end-to-end solution for sustainable mobility, and economically fulfilling the first and last mile, our innovative bike parking products solutions are widely chosen for both public and private bicycle infrastructure. We continue to design and manufacture in Woodinville, Washington – supplying solutions that support sustainability, with usability and quality as guiding design principles.

Sportworks traces its roots back to humble (yet innovative) beginnings.

Sportworks began by manufacturing bicycle handlebars and bar-ends in a space no larger than a garage. In the early 1990's, they expanded their product line and shifted focus to exterior bicycle **racks for transit buses** – originating with King County Metro (Seattle). This breakthrough led to the **industry's first** product that effectively addressed the needs of both bike riders and transit operators, and marked a significant milestone in the field.

The company advanced in its capabilities for bike racks.

As the company progressed in its engineering and design capacities for bike racks, the team became perplexed by the lack of quality in currently available bike parking racks. Most notable was the tendency for racks to scratch bike frames. This deficiency led to the development of the **Tofino™ No Scratch® rack** and a new chapter in the Sportworks story.

Today, Sportworks bicycle racks are used worldwide.

Our interior and exterior bike racks for buses and rail cars are preferred by cyclists and transit operators, and transport more than two million bikes per month worldwide. With a wide range of bike parking solutions at the beginning and end of each journey, Sportworks supplies a comprehensive solution for cycling commuters.

sportworks®